

Modern Optical Fiber – Communication Splitter Transmitter Module

R R RATH¹ and B R MOHAPATRA²

¹*Asst. Prof., Department of Electronics & Communication Engineering, NM Institute of Engineering and Technology, Bhubaneswar, India, rrrretc1@gmail.com*

²*Faculty of Physics, NM Institute of Engineering and Technology, Bhubaneswar, India, brmohapatra2@rediffmail.com*

Received: 22.11.2019 ; Revised : 12.12.2019 ; Accepted : 5.1.2020

Abstract. In this paper, we review both the principles and applications of the fibre Sagnac interferometer. The background theory highlights the need to understand the conditions for reciprocity within the interferometer another through them. The electromagnetic energy traveled, along with the lengths of these cables and was confined in between the two metallic layers. These cables had a loss figure network. The applications range from the expected gyroscopes into the novel hydrophone arrays and intruder detection systems. Immediately its potential for gyroscopic measurements became apparent, and since the first demonstration, substantial research and development investment has evolved a diversity of rotation measuring instruments.

Key Words : Fiber-optic sensor, a chemical sensor, tapered optical fiber, optical chemical sensor, physicochemical transducer.

1. Introduction

Fiber-Optic Communication is the most modern and advanced mode of data communication which has very recent roots dating back to not more than 40 years ago, this was the major breakthrough in the field of communication. Right from this time, there has been a continuously increasing need for bandwidth for communication due to continuously increasing the number of users. More people wanted to communicate, and thus large bandwidths were required thereby forcing communication scientists to look for new possibilities. Communication Scientists all over the world were in an incessant search for a wideband and low-loss medium of data communication which could be used at high data rates with the

least amount of loss possibly. This constant search, for such a medium, led to the development of optical fiber communication. Let us have a quick glimpse into the history of communication [3-6].

1.1 *Aims and scope of the journal*

The journal covers research into the design, characterization, and production of structures scales. The electromagnetic energy traveled, along with the lengths of these cables and was confined in between the two metallic layers. These cables had a loss figure of about 20db/km [7].

When operating frequencies increased further the coaxial cables proved to be inadequate and loss, thereby giving rise to the need of another medium called waveguides. These are basically hollow structures which guide the electromagnetic energy from one point to of about 20db/km. When operating frequencies increased further the coaxial cables proved to be inadequate and loss, thereby giving rise to the need of another medium called waveguides. These are basically hollow structures which guide the electromagnetic energy from one point to another through them. But as the operating frequency further increased to few hundreds of gigahertz these waveguides too proved to be inadequate as there was no supporting electronic circuitry available that could operate at such high frequencies [8].

2. Motivation – Optical Confinement

On the very first look, both the questions seem trivial. This is because we already have a lot of sources of light in our day to day life, for e.g. incandescent bulbs, gas bulbs, LEDs, fluorescent lamps, etc. Then why worry about sources? Similarly, the second question also has a very obvious answer. Fibers are also used for illumination and are wrapped in bundles so that they may opt for a variety of other applications, including sensors and fiber [9] lasers. They are used as light guides in medical and other applications where bright light needs to be shone on a target without a clear line-of-sight path. Many microscopes use fiber-optic light sources to provide intensely [10].

3. Why Optical Fibre

Fibers having attenuations greater than 1 dB/km are rarely used in communication networks. Nevertheless, the attenuation of badly matched fibers may exceed 1 dB/km per connector or splice if they are badly handled during installation stages. A good coupling efficiency requires precise positioning of the

fibers to center the cores. The simplest way to avoid connector losses is by splicing the two ends of the fibers permanently, either by gluing or by fusing at high temperatures. Losses in gaps can be viewed as a type of Fresnel loss because existing air space introduces two media interfaces and their associated Fresnel reflection losses. In this case, there are two major losses to be considered. The first loss takes place on the inner surface of the transmitting fiber, and the second loss occurs due to reflections from the surface of the second fiber. One way of eliminating these losses is by introducing a coupler that matches the optical impedances of the two materials [11-13].

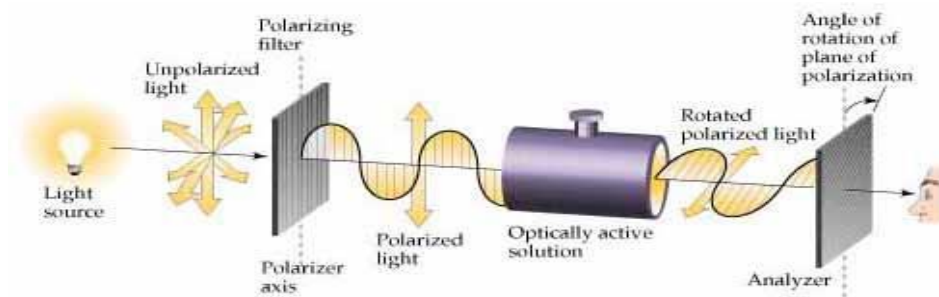

Fig 1. Polarized Light on Fibre Optics

4. Block Diagram

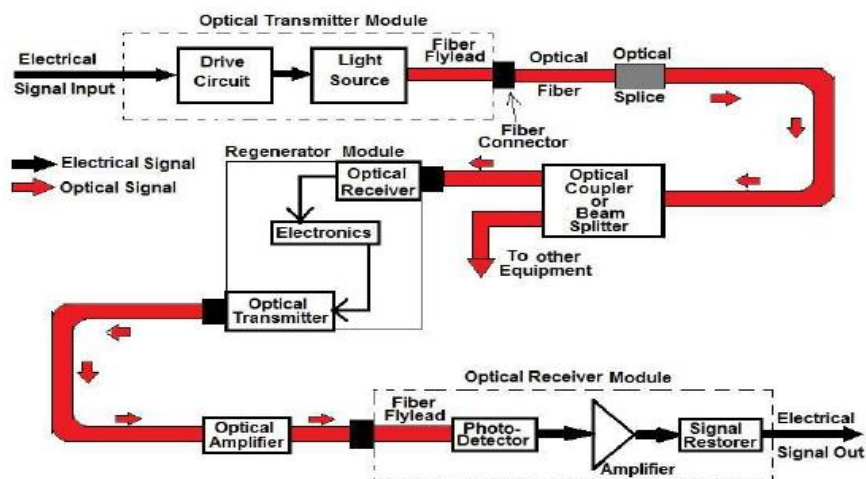

Fig. 2. Block Diagram

5. Scattering Losses of an Optical Fiber

Despite the careful manufacturing techniques, most fibers are inhomogeneous that have disordered, amorphous structures. Therefore, high-order modes suffer more losses, thus causing modal dispersions. The modal dispersion is one of the primary cause of rising time degradation for increasing fiber wavelengths. In addition, propagation time varies with an index of refraction Power losses due to scattering are caused by such imperfections in the core material and irregularities between the junction and cladding as shown in Figure 2 . Inhomogeneities can be either structural or compositional in nature. In structural inhomogeneities, the basic molecular structure has random components, whereas, in compositional inhomogeneity, the chemical composition of the material varies. The net effect from either inhomogeneity is a fluctuation in the refractive index [14]. As a rule of thumb, if the scale of these fluctuations is on the order of $1/10$ or less, each irregularity acts as a scattering center. This is a form of Rayleigh scattering and is characterized by an effective absorption coefficient that is proportional to λ^{-4} . Rayleigh scattering can be caused by the existence of tiny dielectric inconsistencies in the glass [15]. Because these perturbations are small with respect to the waves being propagated, light striking a Rayleigh imperfection scatters in all directions. Scattering losses are less at longer wavelengths, where the majority of the transmission losses are due to absorption from impurities such as ions. Rayleigh scattering losses are not localized, and they follow a distribution law throughout the fiber [18]. However, they can be minimized by having low thermodynamic density fluctuations. A small part of the scattered light may scatter backward, propagating in the opposite direction. This backscattering has important characteristics and may be used for measuring fiber properties. Usually, the inhomogeneities in the glass are smaller than the wavelength λ of the light. The scattering losses in glass fibers approximately follow the Raleigh scattering law; that is, they are very high for small wavelengths and decrease with increasing wavelength λ . In general, optical losses in the glass cause the optical power in fiber to fall off exponentially with the length L of the fiber is 10^{-9} .

6. Applications of Fiber-Optics

- a. Mie Scattering
- b. Rayleigh Scattering

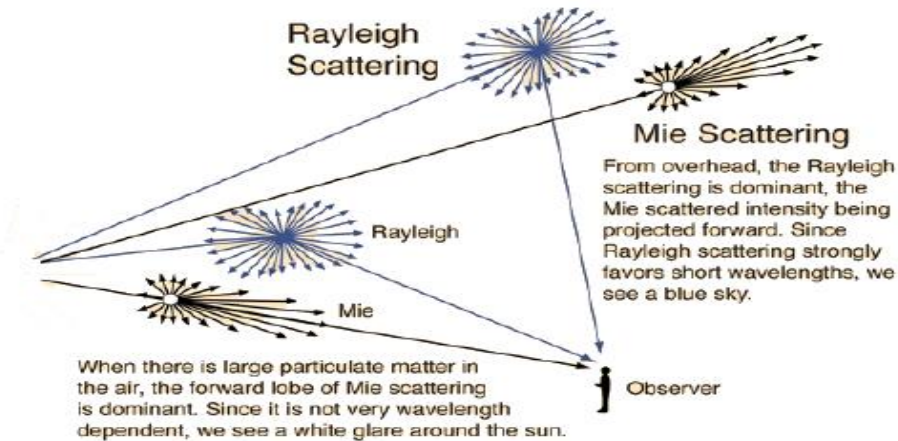

Fig.3. Microband Mie Scattering of Fiber Optics

a. Mie Scattering

Non-perfect cylindrical structure of the fiber and imperfections like irregularities in the core-cladding interface, diameter fluctuations, strains, and bubbles may create linear scattering which is termed as Mie scattering.

b. Rayleigh Scattering

The dominant reason behind Rayleigh scattering is refractive index fluctuations due to density and compositional variation in the core. It is the major intrinsic loss mechanism in the low impedance window. Rayleigh scattering can be reduced to a large extent by using longest possible wavelength .

7. Synthesis of Optical-Fiber

This Chapter is devoted to the description of the optical cable installation methods. Each type of optical fiber cable has a specific strain limit, and special care and arrangements may be needed to ensure successful installation without exceeding it. Some of the most difficult situations for the installation of optical fiber cables are in underground ducts. The condition and geometry of duct routes are of great importance. Damage caused by overloading during installation may not be immediately apparent but can lead to failure later in its service life. Also, aspects related to bending during the installation may require special consideration. Consideration should also be given to factors of time and disturbance. Installation equipment may be required to run for long periods of time and the time of day, noise levels, and traffic disruption should be taken into account.

There are many types of cable installation (underground duct, trenchless, mini-trench, aerial, submarine) are described. Clause 2 deals with additional safety precautions when installing optical cables. In a top-down approach -a large piece of material is cut down to small pieces through different means such as lithography and electrophoresis. In order to obtain a reliable end-to-end network, all different network nodes shall be evaluated using the same methods and metrics . A network node should be able to fulfill its optical functionalities, including the ability to be reconfigured, in all conditions of the environment, in which the node will reside.

8. Results

Attenuation in Transmission Lines

Every transmission line will have some loss, because of the resistance of the conductors and because power is consumed in the dielectric used for insulating the conductors. Power lost in a transmission line is not directly proportional to the line length, but varies logarithmically with the length. For this reason line losses are expressed in terms of decibels per unit length, since the decibel is a logarithmic unit. Calculations are very simple because the total loss in a line is found by multiplying the decibel loss per unit length by the total length of the line. The power lost in a matched line is called matched-line loss. It is usually expressed in decibels per 100 feet. It is necessary to specify the frequency for which the loss applies, because the loss varies with frequency. Conductor and dielectric losses increase with frequency, but not in the same way. The relative amount of each type of loss depends also on the construction on the line, so there is no specific relationship between loss and frequency valid for all types of lines. Actual loss values for practical lines can be found in the following table, expressed in.

Table.1 Frequency of Cable with RG and LMR

| Frequency | LMR | RG |
|-----------|--------------|----------|
| 144 MHz | 5/9" LMR 5.9 | RG - 58 |
| 1.2 GHz | 4/3" MR 4.9 | RG - 213 |
| 2.4 GHz | 3/8" MR 4.3 | RG - 325 |

The power lost in a given line is minimum when the line is terminated in a resistance equal to its characteristic impedance. On non-matched lines, there is an additional loss that increases with the increase of the SWR. This is because the effective values of both current and voltage become greater on lines with standing waves. This increase raises the ohmic losses (I^2R) in the conductors and

the losses in the dielectric (E^2/R). The total loss in a line, including matched-line and the additional loss due to standing waves may be calculated as follows

Total Loss (db.) = $10 \log \alpha^2 - \rho^2 / (\alpha(1 - \rho^2))$ Where, $\alpha = 10ML/10 =$ matched-line loss ratio $\rho = SWR - 1$.

9. Conclusion

The choice of an appropriate emergency restoration method for a damaged optical fiber cable, as well as its permanent repair, depends on the extent of the damage and particularly on the distribution of fiber breaks. The restoration procedures presented below are based on the premise that optical fiber cable systems carry large traffic cross sections and warrant a substantial. Thus, a basic understanding of the mechanics of cable behavior, with regard to the mechanical tension applied to the cable, in damage situations is important in developing and applying these methods. Especially at high optical power levels scattering causes disproportionate attenuation, due to non-linear behavior. Because of this nonlinear scattering, the optical power from one mode is transferred in either the forward or backward direction to the same, or other modes, at different frequencies .

Pump laser at 980 nm or 1480 nm excites erbium doped fiber.

- Erbium fluoresces at 1550 nm, providing stimulated emission gain to the communication signals.
- The doped fiber thus acts much like a laser but without the end mirrors (single pass).
- Spontaneous emission of the erbium is a noise source, so the amplification comes at the expense of reduced SNR.

References

- [1] Report by Allen Consulting Group Pty Ltd for the Australian Govt. Dept. of Broadband, Communications and the Digital Economy, “Quantifying the Possible Economic Gains of Getting More Australian Households online,” http://www.dbcde.gov.au/_data/assets/pdf_file/0004/135508/Quantifying_the_possible_economic_gains_of_getting_more_Australian_households_online.pdf, Nov. 2010.
- [2] CSIRO ICT Centre, “Enabling a revolution in healthcare through e-health innovation,” <http://www.csiro.au/science/healthcare-revolutionthrough-ehealth-innovation.html>.

- [3] Australian Govt. Dept. of Broadband, Communications and the Digital Economy, "National Digital Economy Strategy," <http://www.nbn.gov.au/the-vision/digital-economy-strategy>, 2011.
- [4] In-Line Gas Sensor Based on a Photonic Bandgap Fiber With Laser-Drilled Lateral Microchannels Hartmut Lehmann; Hartmut Bartelt; Reinhardt Willsch; Rodrigo Amezcua-Correa; Jonathan C. Knight *IEEE Sensors Journal*, 2011.
- [5] A Fading-Discrimination Method for Distributed Vibration Sensor Using Coherent Detection of φ -OTDR Fufei Pang; Meeting He; Huanhuan Liu; Xuanwei Mei; Jiang Tao; Tongzhi Zhang; Xiaobei Zhang; Na Chen; Tingyun Wang *IEEE Photonics Technology Letters*, 2016.
- [6] New Bismuth-doped fiber laser operating at 1625–1775 nm E. M. Dianov; S. V. Firstov; S. V. Alyshev; K. E. Riumkin; S. V. Shubin; V. F. Khopin; A. N. Guryanov; O. I. Medvedkov; M. A. Melkumov 2014 *The European Conference on Optical Communication (ECOC)*.
- [7] When to use 3D Die-Stacked Memory for Bandwidth-Constrained Big Data Workloadsason Lowe-Power Mark D. Hill David A. Wood *University of Wisconsin-Madison powerjg,markhill,david@cs.wis.edu*
- [8] Influence of facet reflection on the performance of Vertical-Cavity Semiconductor Optical Amplifiers," *Tikrit Journal for Pure science*, vol. 8, No. 2. 2002.
- [9] Theoretical investigation of spectral linewidth properties of double fused 1.3 μ m MQW-VCA in reflection and transition modes," *Tikrit Journal for Pure Science*, vol. 8, No. 2. 2002.
- [10] *Tikrit Journal of Pure Science*, vol. 9, No. 2. 2003.
- [11] Conductometric studies of 1:1 monosubstituted salicylic/acid in aqueous solution at 25o C," *Science Journal of Chemical, Libya*. 2004.
- [12] C. E. Shannon, *Proc. IRE* 37, 10 (1949).
- [13] K. Fukuchi, T. Kasamatsu, M. Morie, R. Ohira, T. Ito, K. Sekiya, D. Ogasahara, and T. Ono, Paper PD24, *Proc. Optical Fiber Commun. Conf., Optical Society of America*, Washington, DC, (2001)
- [14] P. P. Mitra and J. B. Stark, *Nature* 411, 1027 (2001)
- [15] A. Mecozzi, *IEEE Photon. Technol. Lett.* 13, 1029 (2001)
- [16] J. Tang, *J. Lightwave Technol.* 19, 1104 (2001)
- [17] J. B. Stark, P. P. Mitra, and A. Sengupta *Opt. Fiber Technol.* 7, 275 (2001)
- [18] E. E. Narimanov and P. P. Mitra, *J. Lightwave Technol.* 20, 530 (2002)